

FCP-370S/550S/750S/1100S-IIS Series Expanded Diagram

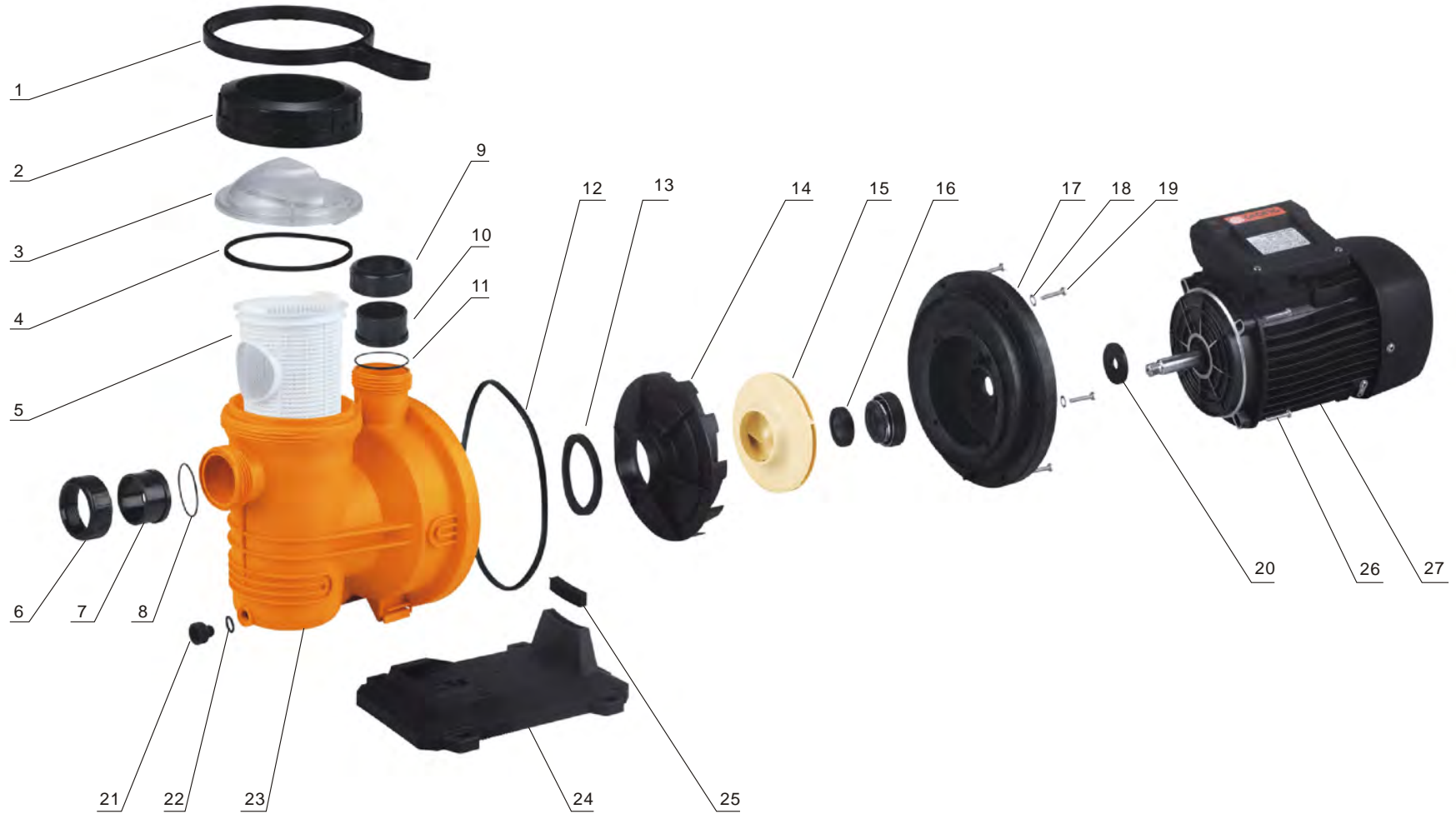

DIAGRAM

No.	Description	No.	Description	No.	Description	No.	Description	No.	Description
1	Handle	7	Inlet Pipe	13	Diffusor O Ring	19	Pump Cover Screw	25	Support Block
2	Strainer Cover Nut	8	Inlet O Ring	14	Diffuser	20	Drop Guard	26	Motor Housing Screw
3	Strainer Cover	9	Outlet Nut	15	Impeller	21	Drain Plug	27	Motor
4	Strainer Cover O Ring	10	Outlet Pipe	16	Mechanical Seal	22	Drain Plug O Ring		
5	Strainer Basket	11	Outlet O-Ring	17	Pump Cover	23	Pump Body		
6	Inlet Nut	12	Pump Body Rubber	18	Washer	24	Pump Support		