

FCP-180S/250S/350S/450S Series Expanded Diagram

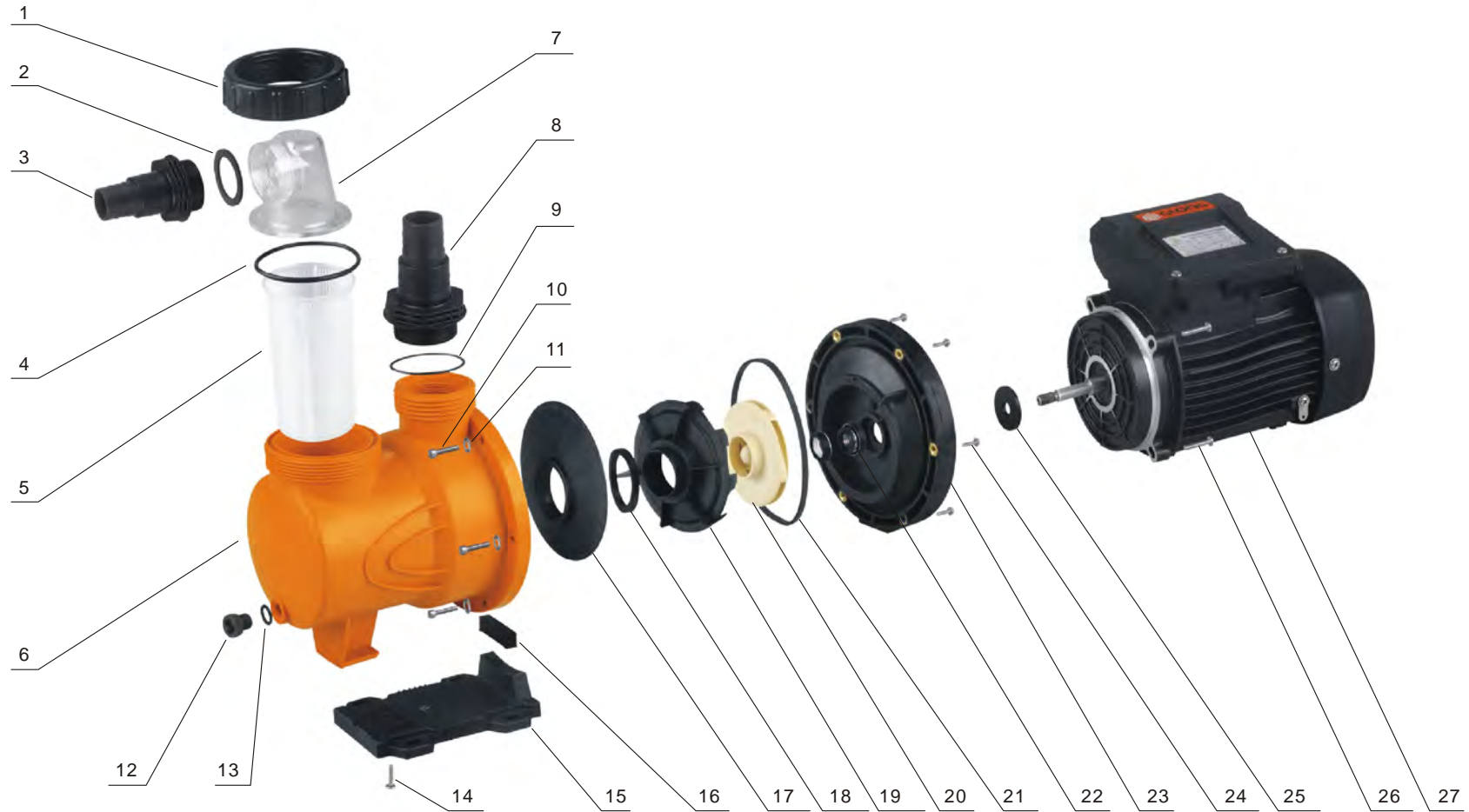

DIAGRAM

N o.	Description	N o.	Description	N o.	Description	N o.	Description	N o.	Description
1	Inlet Nut	7	Strainer Cover	13	Drain Plug O Ring	19	Diffuser	25	Drop Guard
2	Inlet O Ring	8	Outlet Pipe	14	Pump Support Screw	20	Impeller	26	Motor Housing Screw
3	Inlet Pipe	9	Outlet O Ring	15	Pump Support	21	Pump Body Rubber	27	Motor
4	Strainer Cover O Ring	10	Pump Body Screw	16	Support Block	22	Mechanical Seal		
5	Strainer Basket	11	Pump Body Washer	17	Dam-board	23	Pump Cover		
6	Pump Body	12	Drain Plug	18	Diffuser Rubber	24	Pump Cover Screw		